



16237 AVENUE 296 . VISALIA, CA 93292
TEL. (559) 734-7451 1-800-435-5977 FAX (559) 734-7460

INSTALLATION INSTRUCTIONS

REAR STABILIZER BAR

Thank you for purchasing a quality Hellwig Product.

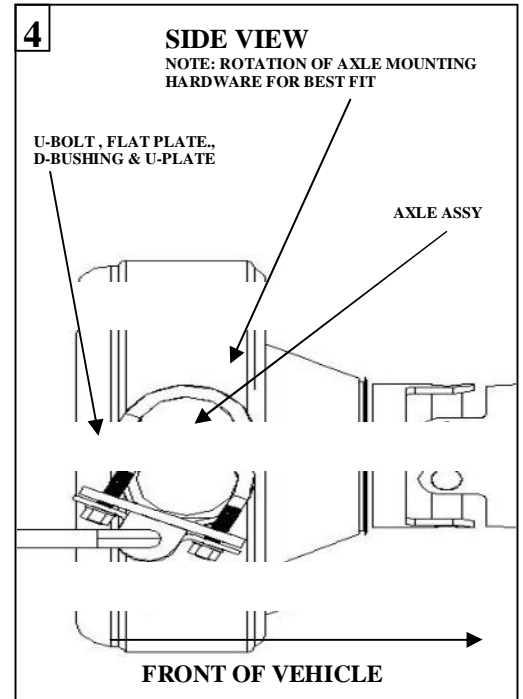
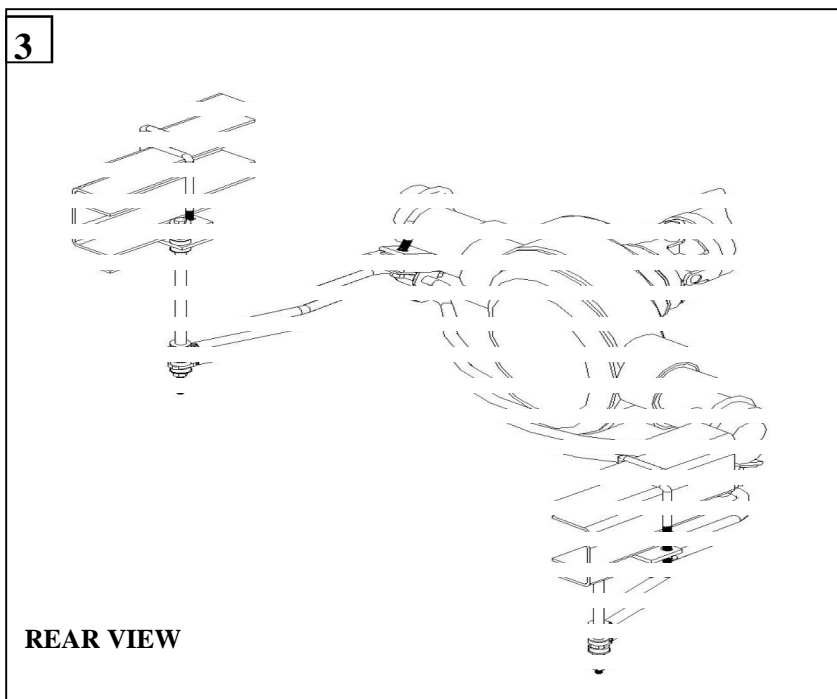
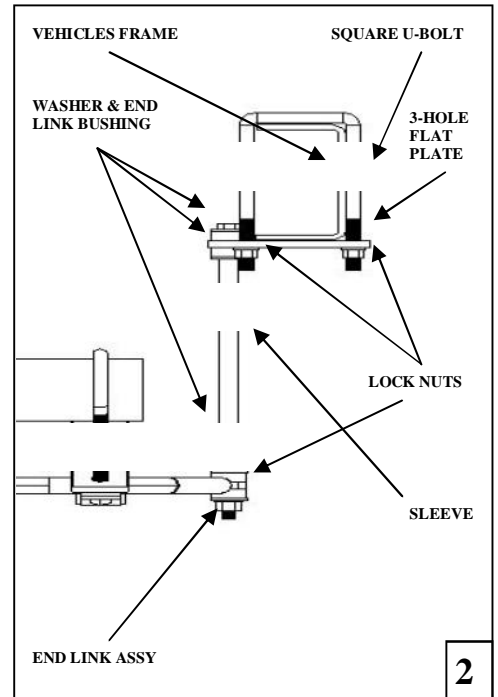
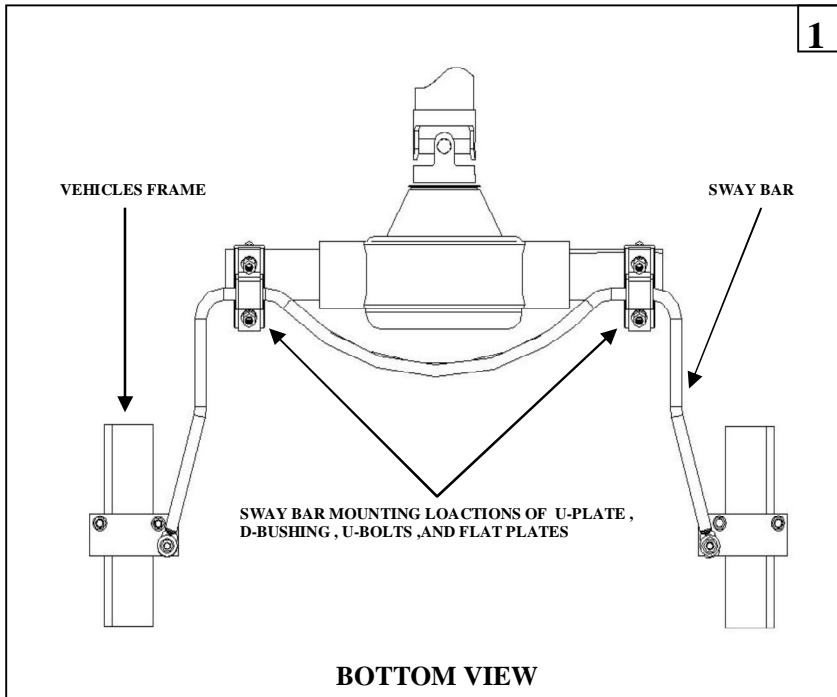



16237 AVENUE 296 . VISALIA, CA 93292
TEL. (559) 734-7451 1-800-435-5977 FAX (559) 734-7460

TORQUE TABLE

BOLT SIZE: 3/8" = 20-30 ft. lbs. – 7/16" = 35-45 ft. lbs. – 1/2" = 50-70 ft. lbs. – 9/16" = 70-90 ft. lbs.

SAFETY: BEFORE STARTING YOUR INSTALLATION, BE SURE TO SET PARKING BRAKE AND CHOCK TIRES.

NOTE: TO EASE INSTALLATION AND TO PROPERLY ADJUST BAR, THE WEIGHT OF THE VEHICLE MUST BE ON THE SUSPENSION, AS IF DRIVING DOWN THE ROAD. DO NOT RAISE VEHICLE BY FRAME.

1. Place the U-bolts on the axle pointing down. Be careful as not to damage the electrical wires, fuel or brake line mounted on the axle. **SEE PHOTO (4).**
2. Place the D-bushing on the sway bar in the area between the arms and the sway bar hump. **SEE PHOTO (1).** Position the U-plate over the D-bushings, raise the sway bar to the vehicle's axle. Insert the U-bolts thru the U-plate holes slightly tighten with hex nuts, enough to support the sway bar. U-bolts can be moved at the axle for best fit, also on the D-bushings on the sway bar. **LEAVE LOOSE AT THIS TIME TO ALLOW FOR ADJUSTMENT LATER.**
3. Locate the cross member mount at the vehicle's frames (spare tire area). Take the square U-bolts and hang them on the frames. **SEE PHOTO (2).**
4. Locate the 3-hole flat plates there is a left and right. Assemble the end link assemblies washer, bushing, 3-hole flat plate, bushing, washer and sleeve. **SEE PHOTO (2).**
5. Raise the sway bar arms to the end link assembly. With sleeve on end link insert washer, bushing. Insert end link thru eye of the sway bar arm, insert bushing, washer and lock nut. Do the same for the opposite side. Tighten the end link assemblies just enough that the bushings start to bulge. Over tightening can cause damage to the bushings.
6. Rotate axle u-bolts to make the end links a straight up and down as possible, and the sway bar centered at the axle. Torque all mounting hardware to specified rates.
7. Test drive your vehicle recheck your installation readjust as needed. Check for clearance on all undercarriage components; vehicle's springs, exhaust system, brake and fuel lines. Recheck your installation on a regular monthly basis thereafter.

ATTENTION INSTALLER: BE SURE THAT THE CUSTOMER RECEIVES THIS INSTRUCTION SHEET, ALL IMPORTANT NOTE CARDS AND THE WARRANTY FORM



16237 AVENUE 296 . VISALIA, CA 93292
TEL. (559) 734-7451 1-800-435-5977 FAX (559) 734-7460

PARTS LIST

RSB KIT # 7528

PART #	QTY	DESCRIPTION
20217528	1	3/4" SWAY BAR
20907528	1	COMPLETION KIT
118000502	2	1/2" X 3-1/4" X 5" SQUARE U-BOLT
111000496	2	3/4" POLY BUSHING
20800430	2	U-PLATE
20800350	2	FLAT PLATE
118020480	2	1/2" X 3" X 4-1/4" ROUND U-BOLT
101500751	2	7/16" X 9" END LINK
20800222	2	5/8" X 5-7/8" END LINK SPACER
125030336	1	BUSHING BAG # BG-336
111000389	8	END LINK BUSHING
125020149	1	SMALL APRTS BAG # BG-149
102420041	8	7/16" FLAT WASHER
102520043	8	1/2" FLAT WASHER
105521044	16	1/2" HEX NUT
107700080	2	7/16" LOCK NUT
135000257	1	INSTRUCTION SHEET (R-257)